

Technical Manual



JBL AC28/95-WH

SPECIFICATIONS

ACOUSTIC & ELECTRICAL SPECIFICATIONS:

- Nominal Impedance: 8 Ohms
- System Input Power Rating: 375W Continuous Pink Noise, 750W Program, 1500W Peak
- Frequency Response: 60 Hz - 18 kHz (± 3 dB)
- Frequency Range: 47 Hz - 20 kHz (-10 dB)
- System Sensitivity: 94 dB (1 Watt @ 1 Meter)
- Maximum SPL: 120 dB SPL Continuous
- Crossover Frequency: 2 kHz

SYSTEM COMPONENTS:

- Cabinet: Enclosure (Not for Sale)
- Grille: 365012-001, 365012-101(WH)
- Low Frequency Transducer: (2) 228J, 205 mm (8 in.) Cone Transducer
- DC Resistance: 11.3 ohms
- High Frequency Transducer: 2408H-1, 25 mm (1 in.) Exit Compression Driver

SYSTEM COMPONENTS: (CONT'D)

- DC Resistance: 4.8 ohms ± 0.2 ohms
- Crossover Network: 365060-001

AURAL SWEEP TEST SPECIFICATIONS:

- A. System Aural Sweep Test: 7.0V Input, 20 Hz to 20 kHz
- B. L.F. Aural Sweep Test: 7.0V Input, 10 Hz to 2 kHz
- C. H.F. Aural Sweep Test: 0.75V Input, 200 Hz to 20 kHz

PHYSICAL SPECIFICATIONS:

- Enclosure Dimensions: 679.5 x 237.5 x 254.0 mm D (26.8 x 9.4 x 10.0 in.D.)
- Shipping Weight: 40.9 lb (18.6 kg.)

WARRANTY INFORMATION:

- Refer to Warranty Statement packed with each product.

PACKAGE

Warranty 59660
Specification Sheet
365228-001

Carton
365073-001

Filler (2)
365074-001

PKG, Microfoam (2)
49790P
20" X 18" sheets

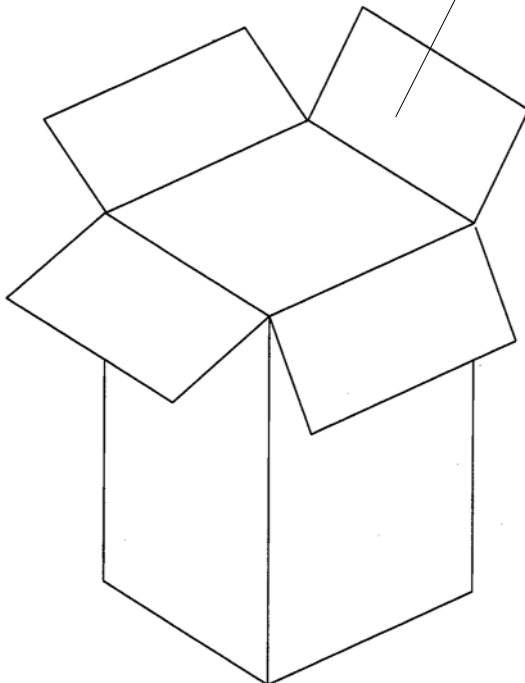

WIRING DIAGRAM

Driver, Low Freq (2)
228J
(365227-002)

Driver, High Freq
2408H-1
(365011-001X)
Diaph Repl
D8R2408-1

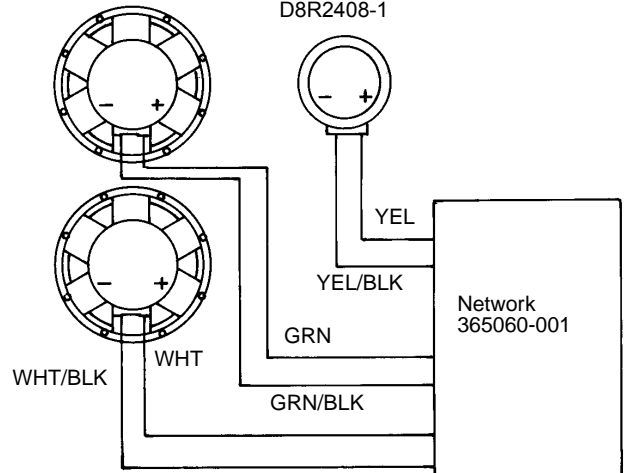

SEE NETWORK SCHEMATIC PAGE

NOTE: INDIVIDUAL PARTS FOR THE ABOVE CROSSOVER ARE NOT AVAILABLE. A COMPLETE REPLACEMENT ASSEMBLY SHOULD BE ORDERED.

JBL AC28/95-WH

SCHEMATIC (365060-001)

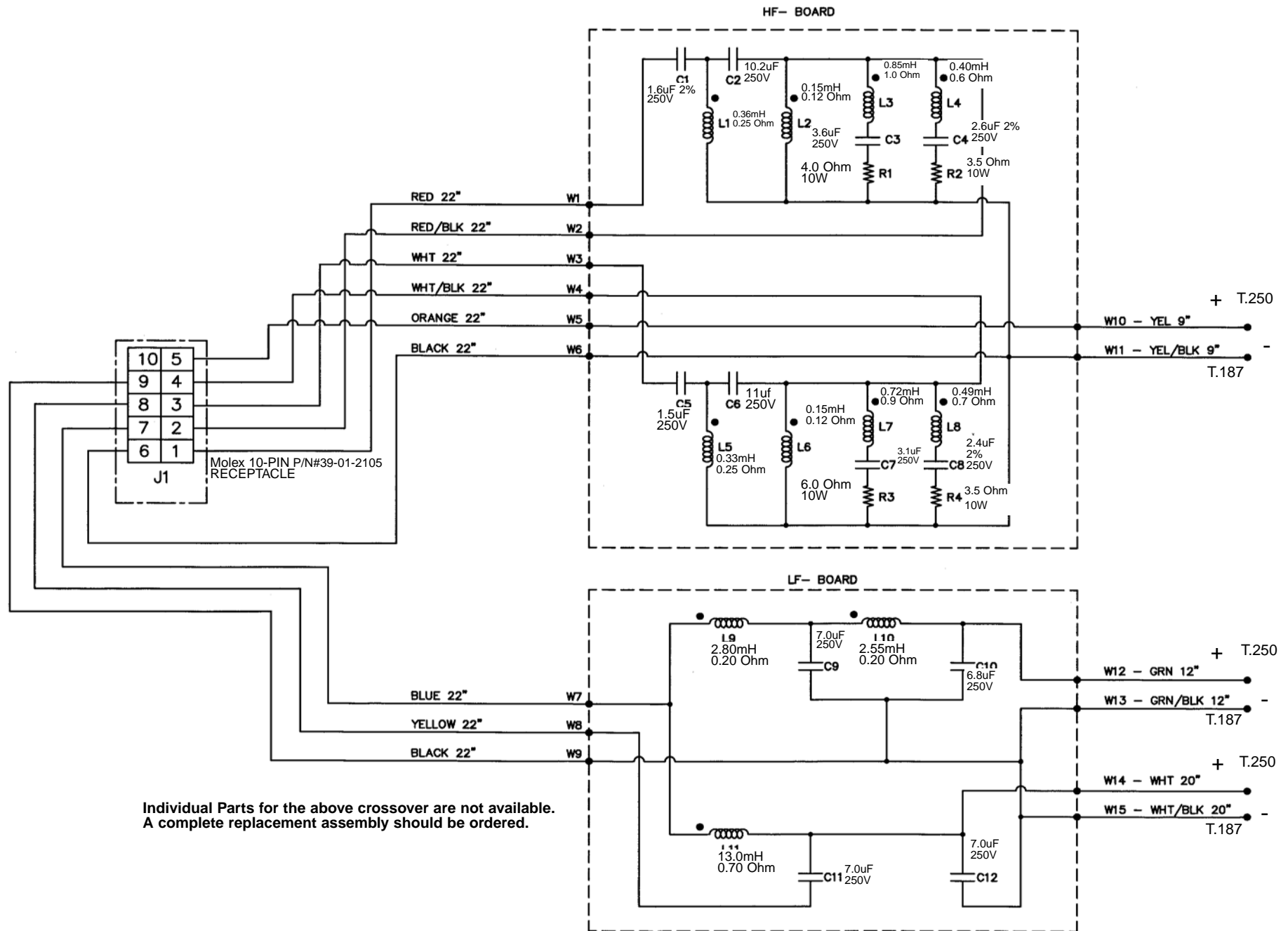

JBL AC28/95-WH

JBL AC28/95-WH

COMPONENT EXPLODED VIEW

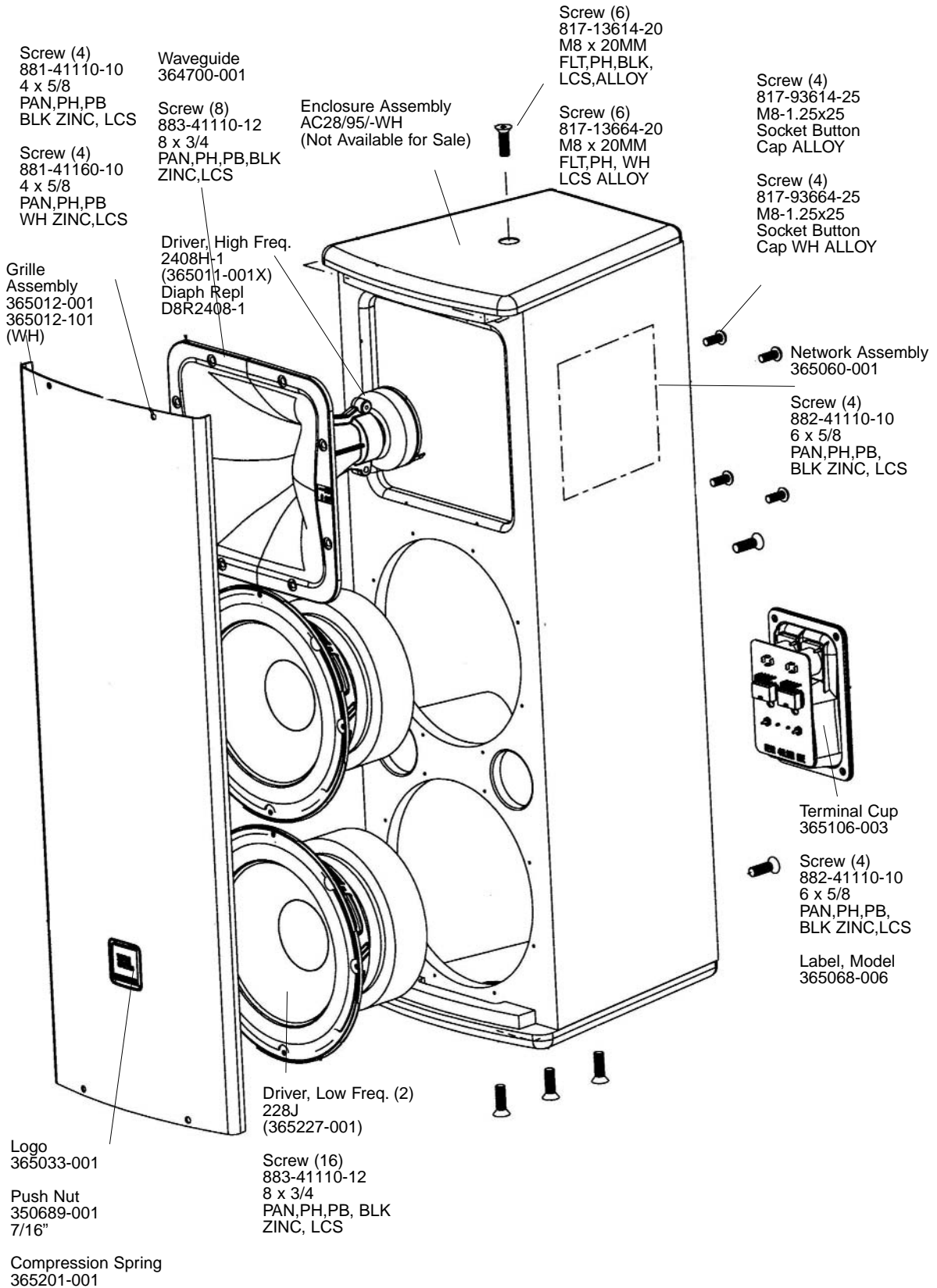

JBL AC28/95-WH