

Technical Manual

JBL2240G/H

SPECIFICATIONS



ACOUSTIC & ELECTRICAL SPECIFICATIONS:

- Nominal Impedance: 4 ohm (G) / 8 ohm (H)
- Power Capacity: 600W Continuous Program
- Frequency Range: 30 Hz to 2 kHz
- Sensitivity: 98 dB SPL*
- Crossover Frequencies: N/A

SYSTEM COMPONENTS:

- Cabinet: N/A
- Grille: N/A
- Low Frequency Transducer: 460mm (18 in.) Cone Transducer (2240G/H)
- DC Resistance: 2.5 ohm \pm 10% Copper Wire (G)
6.0 ohm \pm 10% Copper Wire (H)

AURAL SWEEP TEST SPECIFICATIONS:

- A. L.F. Aural Sweep Test: 7.0V Input, 20 Hz to 1.2 kHz (G)
- L.F. Aural Sweep Test: 15.0V Input, 20 Hz to 1.2 kHz (H)

PHYSICAL SPECIFICATIONS:

- Enclosure Dimensions: 464mm x 464mm x 187mm D (18.25 x 18.25 x 7.25 in. D)
- Shipping Weight: 32 lbs. (14.5 kg)

WARRANTY INFORMATION:

- Refer to the Warranty Statement packed with each product.

*1 Watt (2.0 V RMS) @ 1 Meter (G)

*1 Watt (2.83 V RMS) @ 1 Meter (H)

PACKAGE

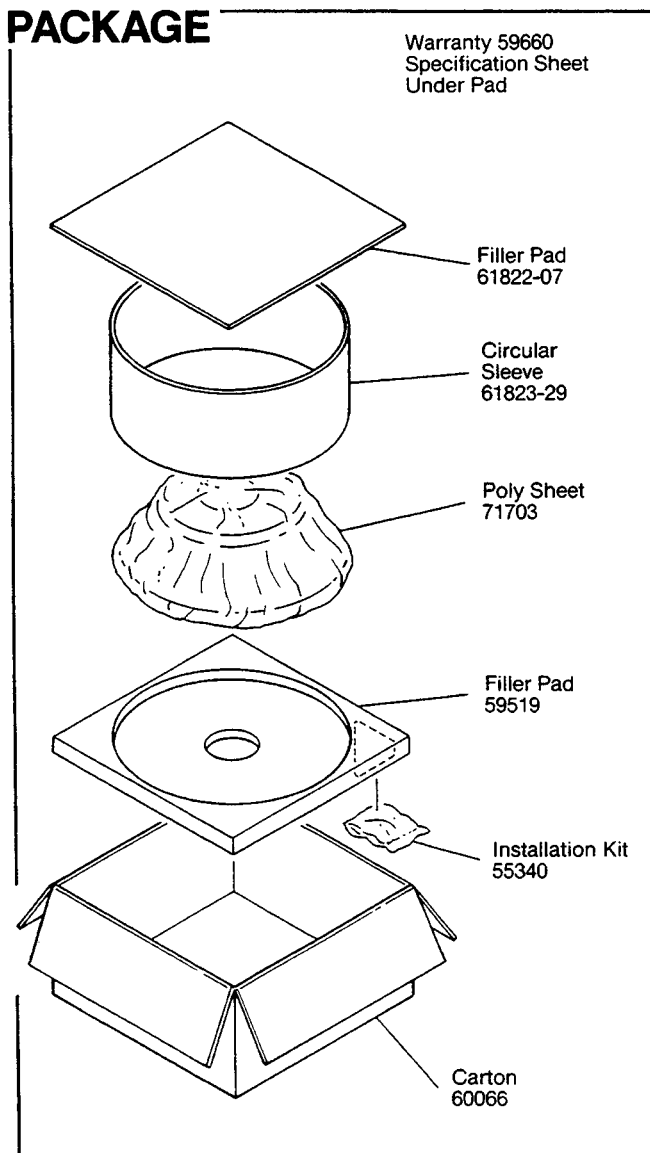

COMPONENT VIEW

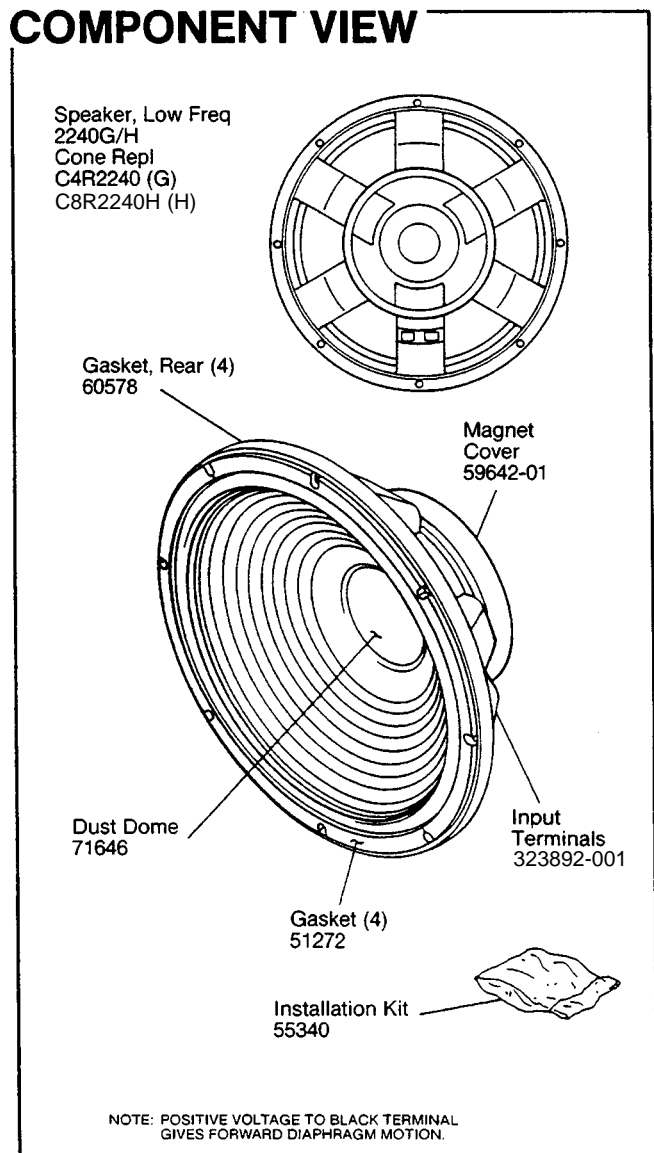

JBL2240G/H REV D

JBL2240G/H

MECHANICAL DRAWING

THESE DRAWINGS AND SPECIFICATIONS ARE THE PROPERTY OF JBL. INCORPORATED. THEY ARE ISSUED IN STRICT CONFIDENCE AND SHALL NOT BE REPRODUCED, COPIED, OR USED AS THE BASIS FOR MANUFACTURE OR SALE OF APPLIANCES WITHOUT WRITTEN PERMISSION.

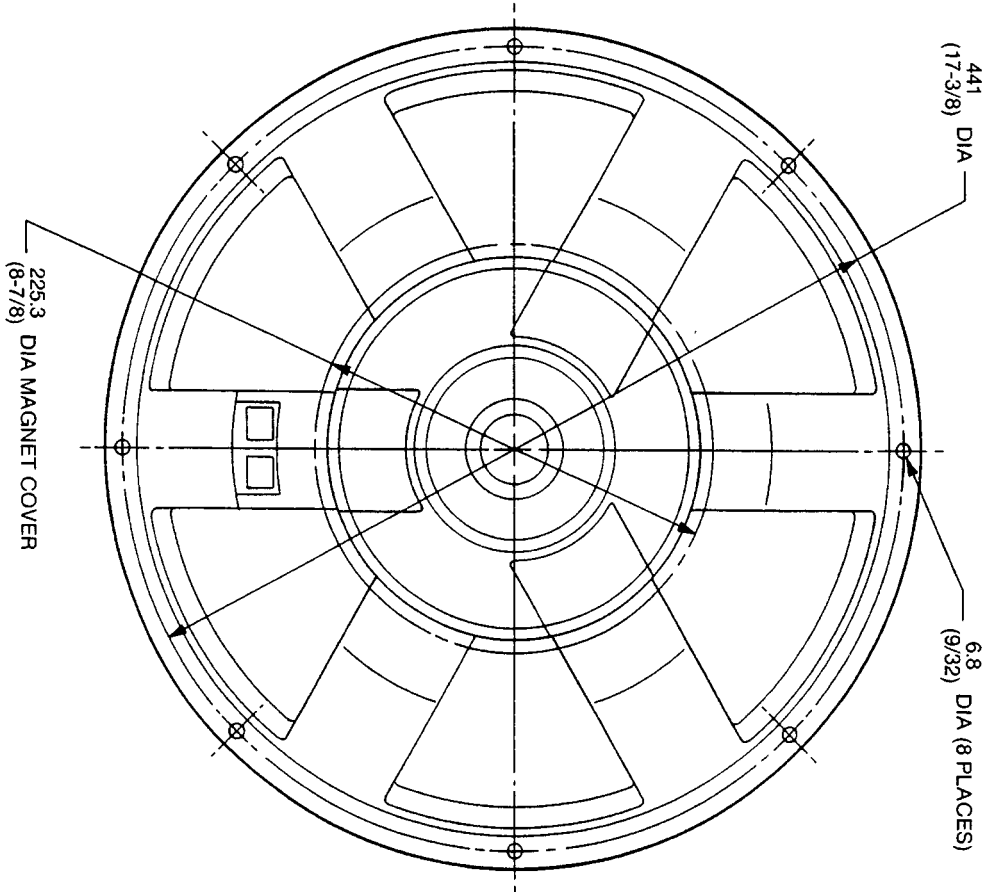
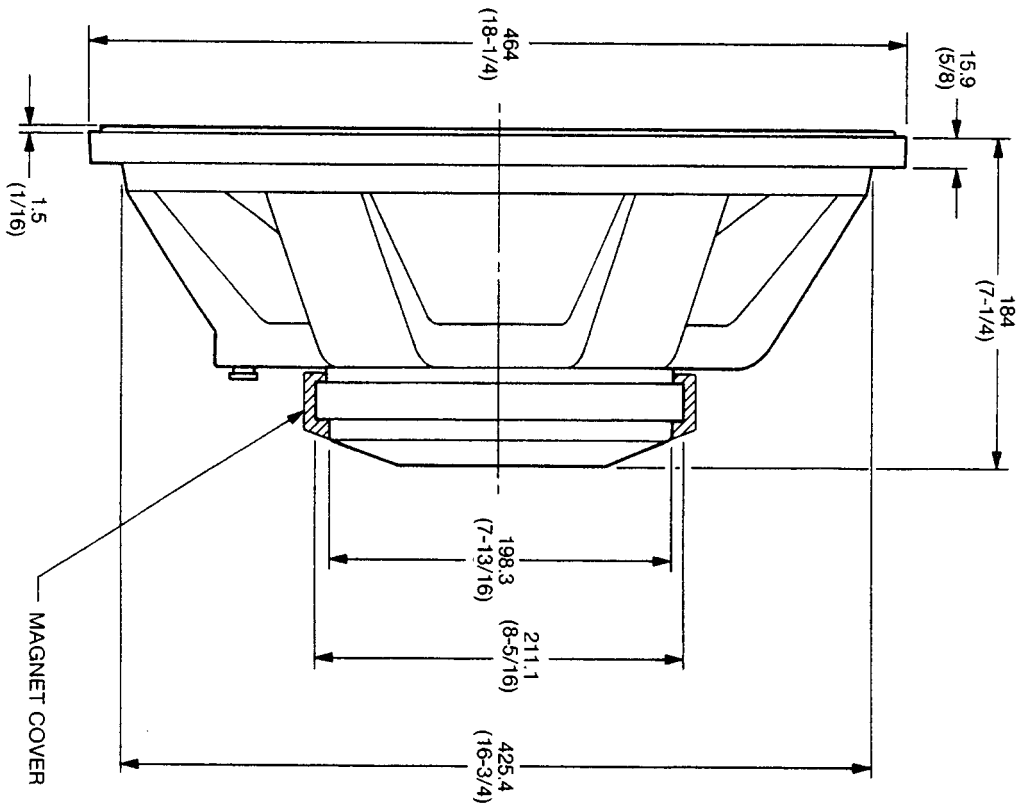

ALL DIMENSIONS ARE REF. ONLY
NOTE: DIMENSIONS IN () ARE IN INCHES

JBL2240G/H