

Technical Manual

JBL G135-8, (A-8)

SPECIFICATIONS



ACOUSTIC & ELECTRICAL SPECIFICATIONS:

- Nominal Impedance: 8 ohm
- Power Capacity: 200W
- Frequency Range: 50 Hz to 6000 Hz (-8)
40 Hz to 6000 Hz (A-8)
- Sensitivity: 104 dB SPL* (-8)
102 dB SPL* (A-8)
- Crossover Frequencies: N/A

SYSTEM COMPONENTS:

- Cabinet: N/A
- Grille: N/A
- Low Frequency Transducer: 380mm (15 in.) Cone Transducer (G135-8, (A-8))
- DC Resistance:

AURAL SWEEP TEST SPECIFICATIONS:

- L.F. Aural Sweep Test:

PHYSICAL SPECIFICATIONS:

- Enclosure Dimensions: 391mm x 391mm x 170mm D
(15.38 x 15.38 x 6.68 in. D)
- Net Weight: 13 lbs. (5.9 kg.)

WARRANTY INFORMATION:

- Refer to the Warranty Statement packed with each product.

*1 Watt (2.83 V RMS) @ 1 Meter

PACKAGE

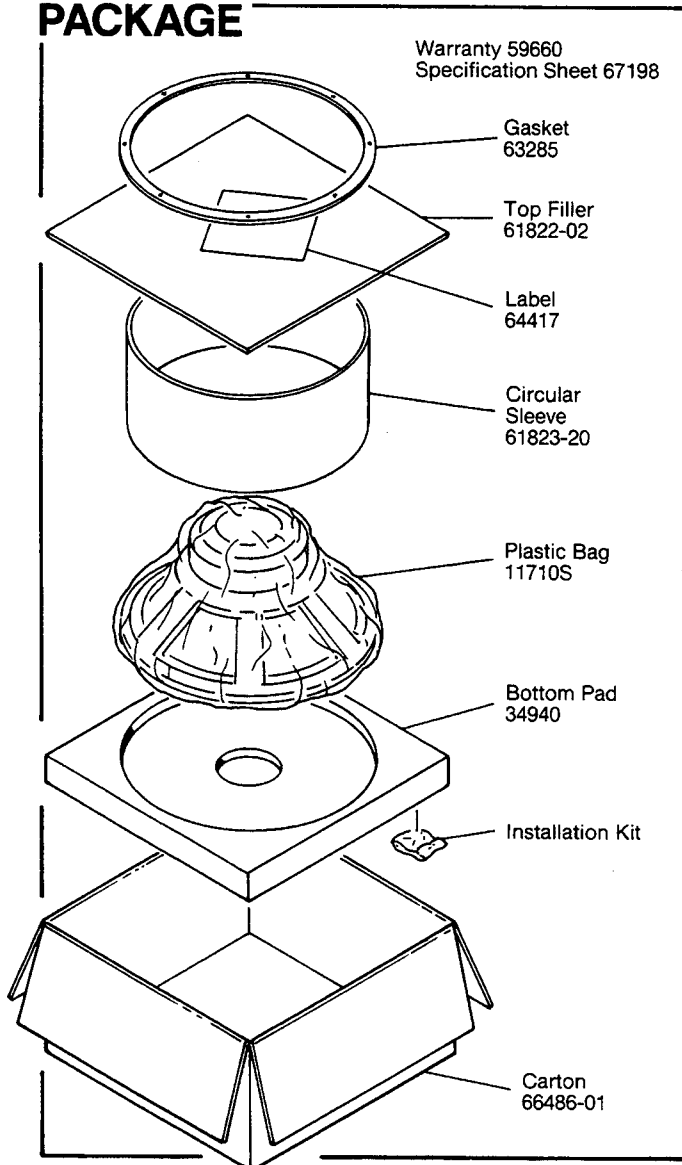

COMPONENT VIEW

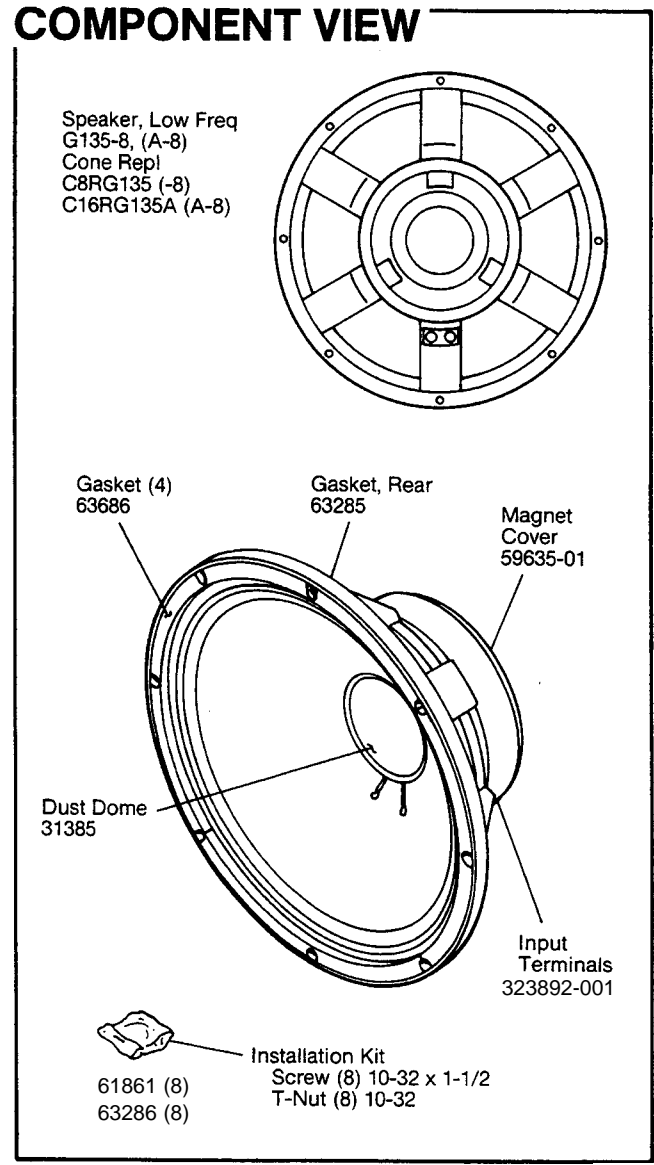

JBL G135-8, (A-8) REV C

JBL G135-8, (A-8)

MECHANICAL DRAWING

THESE DRAWINGS AND SPECIFICATIONS ARE THE PROPERTY OF JBL. INCORPORATED. THEY ARE ISSUED IN STRICT CONFIDENCE AND SHALL NOT BE REPRODUCED, COPIED, OR USED AS THE BASIS FOR MANUFACTURE OR SALE OF ANY PARTS WITHOUT WRITTEN PERMISSION.

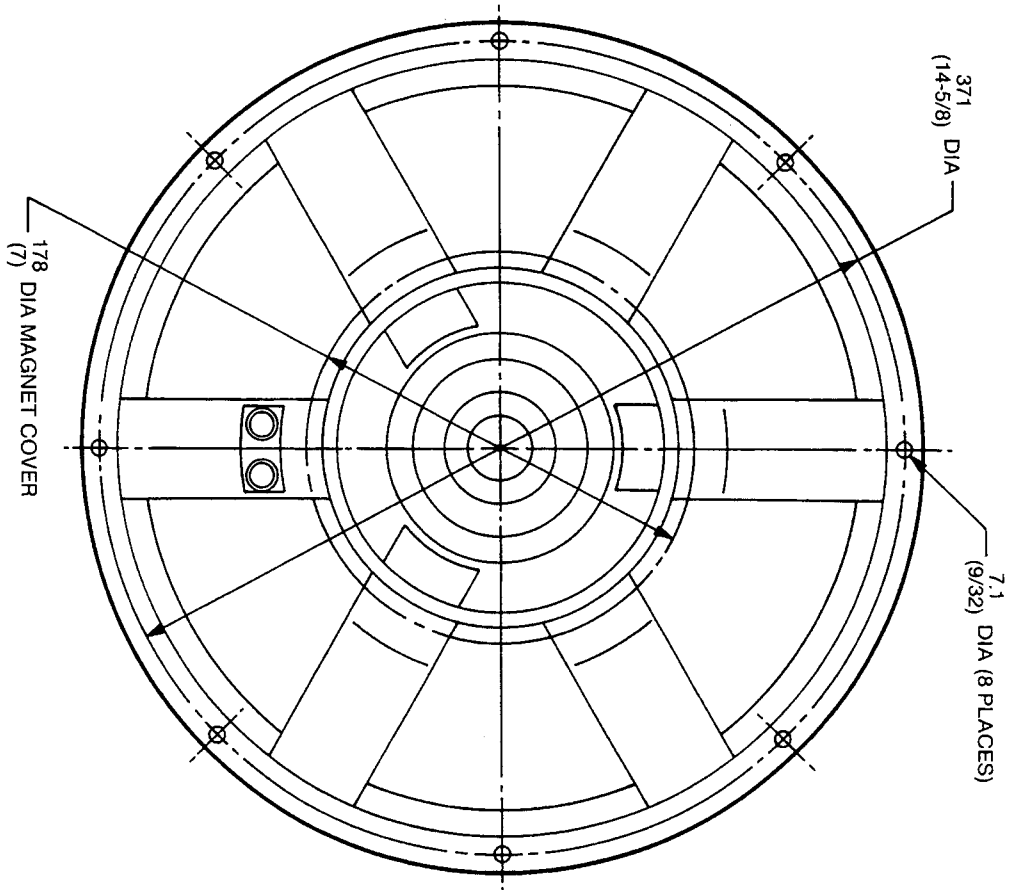
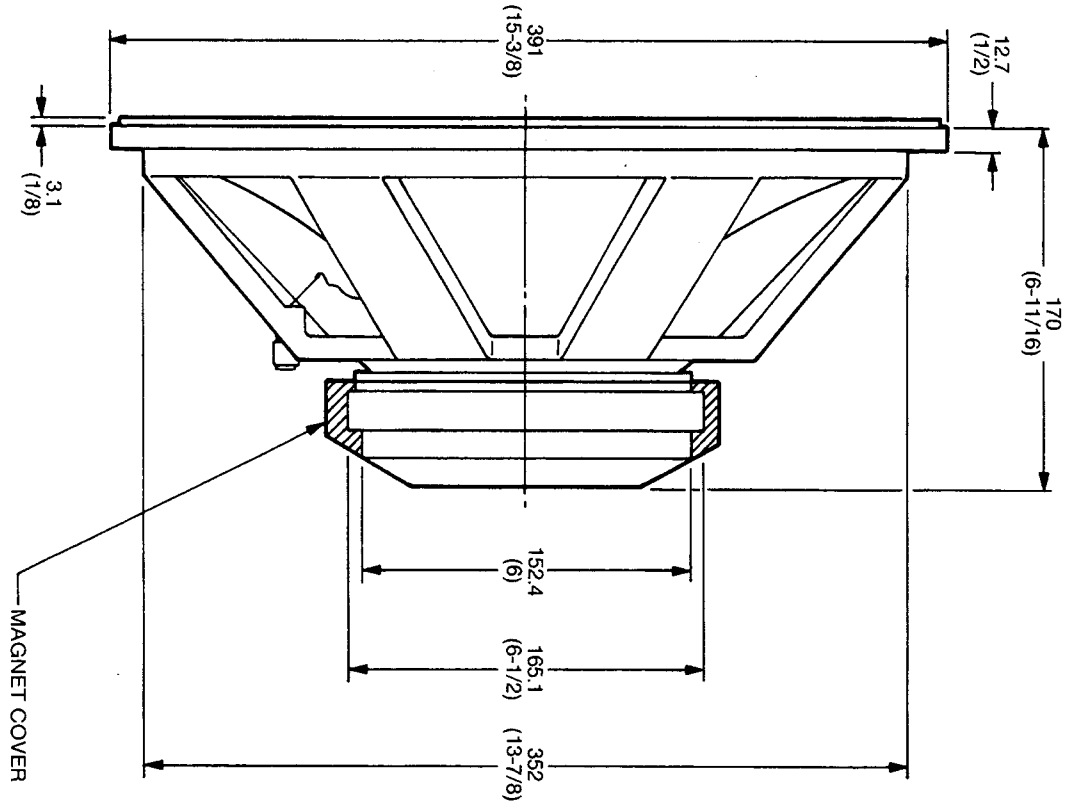

ALL DIMENSIONS ARE REF. ONLY
NOTE: DIMENSIONS IN () ARE IN INCHES

JBL G135-8, (A-8)