

DRAWING NUMBER ISSUE
S-B261BA-02

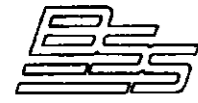

BSS Audio

HARMAN INTERNATIONAL
INDUSTRIES LIMITED
CRANBORNE HOUSE
CRANBORNE ROAD
POTTERS BAR
HERTS
EN6 3JN
Tel 01707 660667
Fax 01707 660755

BSS AUDIO LTD
MASTER

TITLE: 261 FRONT PANEL
COMP SIDE ASSY

SHT 1 OF 2

FILENAME: S-B261B-02.LAY

DRAWN: PST

DATE: 23/09/99

CHECKED: PT 27/07/00

MATERIALS:

FINISH:

ALL DIMENSIONS IN mm

ISSUE COMMENTS:

1. PRE-PRODUCTION RELEASE
2. PRODUCTION RELEASE 21/07/00

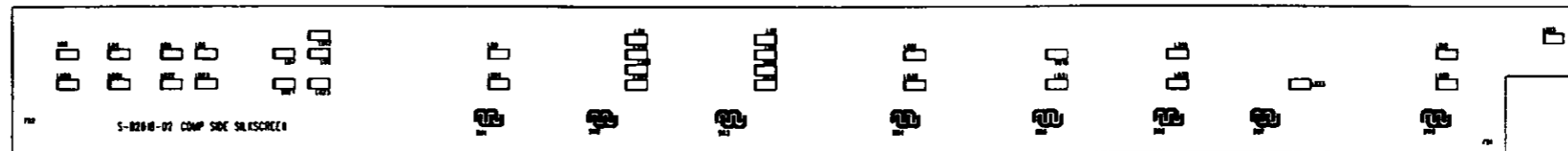

COMPONENT SIDE VIEW

337604 X1
[Signature] 27/07/00
337604-001 FRONT PANEL ASSY, ENCL CONTROLLER

SORTED BY: SEQUENCE NO.
EFFECTIVE: 28/11/00

REQUESTED BY: JSOPPITT

COMPONENT PART NUMBER	BOX	SEQ	DESCRIPTION	QTY UM	COMPONENT REFERENCES
AA		REF	***PROCESS SHEET ISSUE***	1.000 EA	REV01 - INTRODUCED TO PRODUCTION REV.02-ECN0346-S-B261B-01 NOW ISSUE 02
AS0222R-0805F		010	SM0805 RES 2K2 1% 0.1W T200	1.000 EA	R20
AS0331R-0805F		010	SM0805 RES 330R 1% 0.1W T200	33.000 EA	R1,2,3,4,5,6,7,8,9,10,11,12,13,14,15,16,17,18,19,21,22,23 24,25,26,27,28,29,30,31,32,33,34
BS0013R-SOT23		010	BAV70 SM DUAL DIODE COM CATH	4.000 EA	D1,2,3,4
BS2108R-S016		010	74HC595 SM 8BIT+LATCH	5.000 EA	IC1,2,3,4,5
CS1221R-1206J		010	CAP CRMC 220PF 5% 50V NP0	1.000 EA	C6
CS7104R-1206K		010	CAP CRMC 100NF 10% 50V X7R	5.000 EA	C1,2,3,4,5
FF10064		010	CONNECTOR FCC VERT 10 WY XL04-	1.000 EA	CN1
JS0004		010	LED RED SML-010UT	7.000 EA	LD1,3,4,5,6,7,8
JS0005		010	LED YEL SML-010YT	10.000 EA	LD2,10,11,14,15,16,19,26,29,30
JS0006		010	LED GRN SML-010PT	15.000 EA	LD9,12,13,18,20,21,22,23,24,25,27,28,31,32,33

ITEMS LIST 261B PCB ASSY SM

PART NO. R-B261B-02-SM

REFERENCE

28/11/2000 14.55.54

PAGE 2

COMPONENT
PART NUMBER

BOX

SEQ

DESCRIPTION

QTY
UM

COMPONENT REFERENCES

S-B261B-02

010 PCB FRONT PANEL BRD.-B261

1.000
EA

----- * END OF REPORT PCP010P * -----

PART / DRG. NUMBER
P-B261BJ-01

TITLE.
**JBL-B2 CONTROLLER
OVERLAY ALIGNMENT JIG**
Sheet 1 of 1

MATERIAL.
BASE - 1.6 THK ZINTEC
PINS - STAINLESS STEEL

FINISH.
CLEAN

DETAILS:

ISSUE COMMENTS. (FOR REFERENCE ONLY)

FILENAME.

DRAWN. PB

DATE. 14.2.00

CHECKED.

ALL DIMENSIONS ARE IN millimetres.
DIMENSION TOLERANCE.
DIMENSION TO 1 DECIMAL PLACE IS $\pm 0.25\text{mm}$
DIMENSION TO 2 DECIMAL PLACES IS $\pm 0.1\text{mm}$
ANGULAR TOLERANCE IS $\pm 0.5^\circ$.

THIRD ANGLE

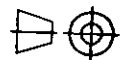

Harman International Industries Ltd.
Cranborne House,
Cranborne Road,
Pokers Bar,
Hertfordshire EN6 3JN
UK.
Tel. 01707 660667
Fax. 01707 660755

THIS DRAWING IS THE COPYRIGHT OF BSS AUDIO AND C-AUDIO. ALL
REPRODUCTION AND COPYING, OTHER THAN THAT FOR LICENSED MANUFACTURERS
OWN INTERNAL USE, OR DISCLOSURE OF PART OR WHOLE TO A THIRD PARTY
WITHOUT PRIOR WRITTEN AUTHORISATION IS IN VIOLATION OF THE COPYRIGHT.
© BSS AUDIO & C-AUDIO 2001

DO NOT SCALE

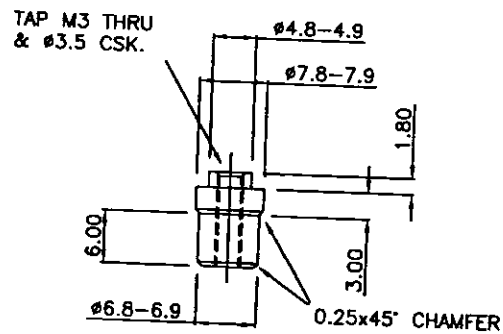

3 off PINS REQUIRED PER JIG.
Scale 2:1

**BSS AUDIO LTD
MASTER**

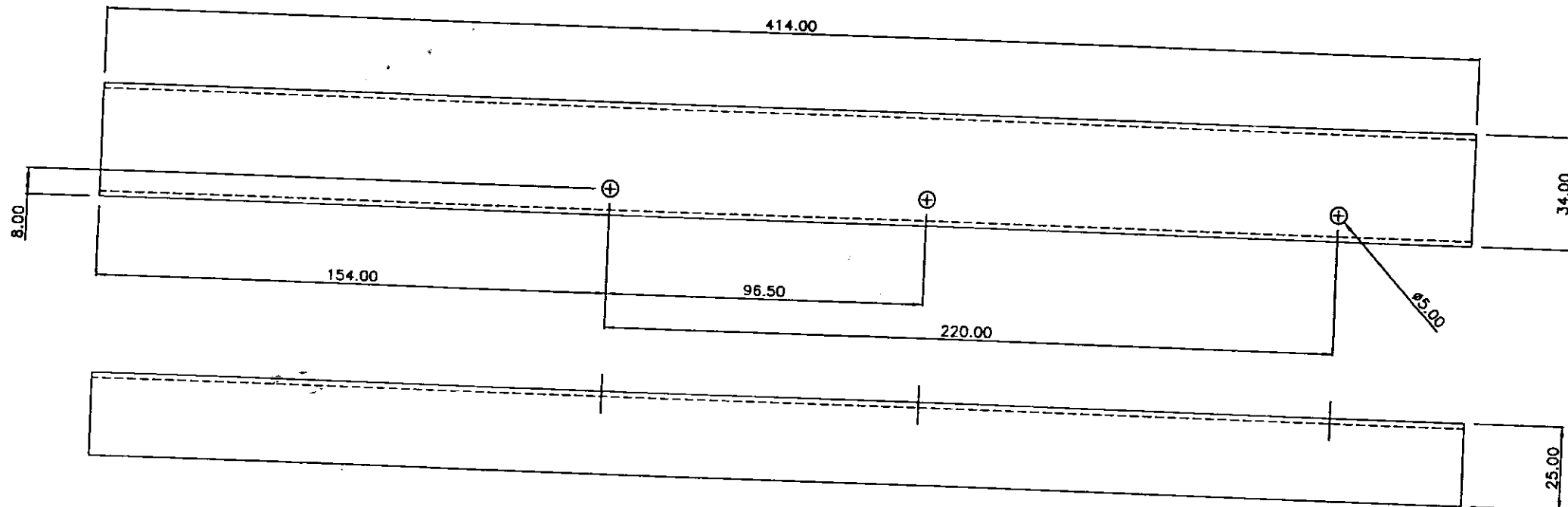

BASE ASSEMBLED WITH PINS

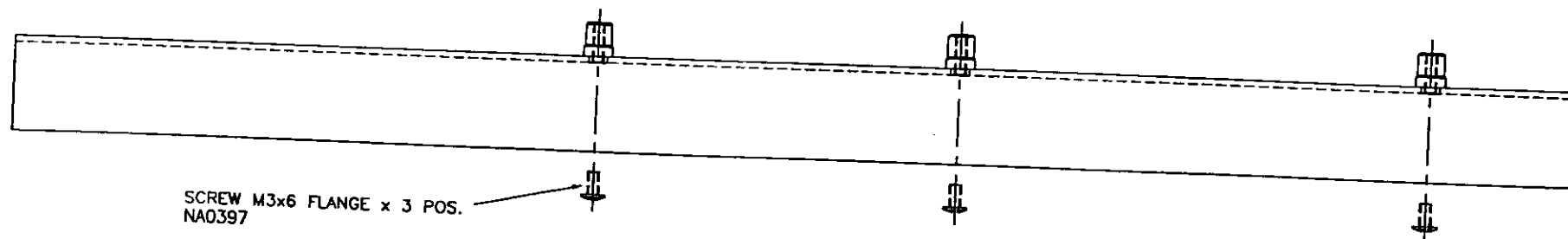

REMOVE ALL BURRS & SHARP EDGES

DRAWING NUMBER

S-B261BR-02

DO NOT SCALE

STOCK REF

S-B261B-02



CRANBORNE HOUSE
CRANBORNE ROAD
POTTERS BAR
HERTS EN8 3JN
ENGLAND

Phone 01707 880887
Fax 01707 880755

BSS Audio.

BSS AUDIO LTD
MASTER

TITLE

B261 DISPLAY PCB
MOTHERPANEL

PCB ROUTING DETAILS
54 POSITIONS
SCALE 4:1

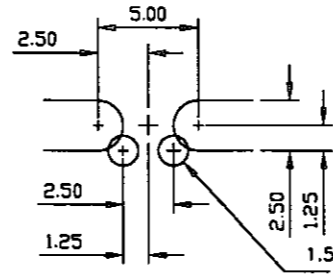

FILENAME S-B261BR-02

DRAWN AW

DATE 24-09-99

CHECKED FT 27/07/06

MATERIAL:

FINISH:

DETAILS

1. USE A #2.5 TOOL TO PROFILE IN THE POSITIONS SHOWN
2. MATERIAL 1.6mm GLASS FIBRE
1oz CU DOUBLE SIDED P.T.H. GOLD
FLAMMABILITY RATING TO 94-V0
3. SOLDER RESIST BOTH SIDES IN GREEN
4. LEGEND ON BOTH SIDES IN WHITE

ISSUE COMMENTS (REF. ONLY)

- P1. FIRST PROTOTYPE 24-09-99
1. PRE-PRODUCTION RELEASE 8/12/99
 2. PRODUCTION RELEASE 21/07/00

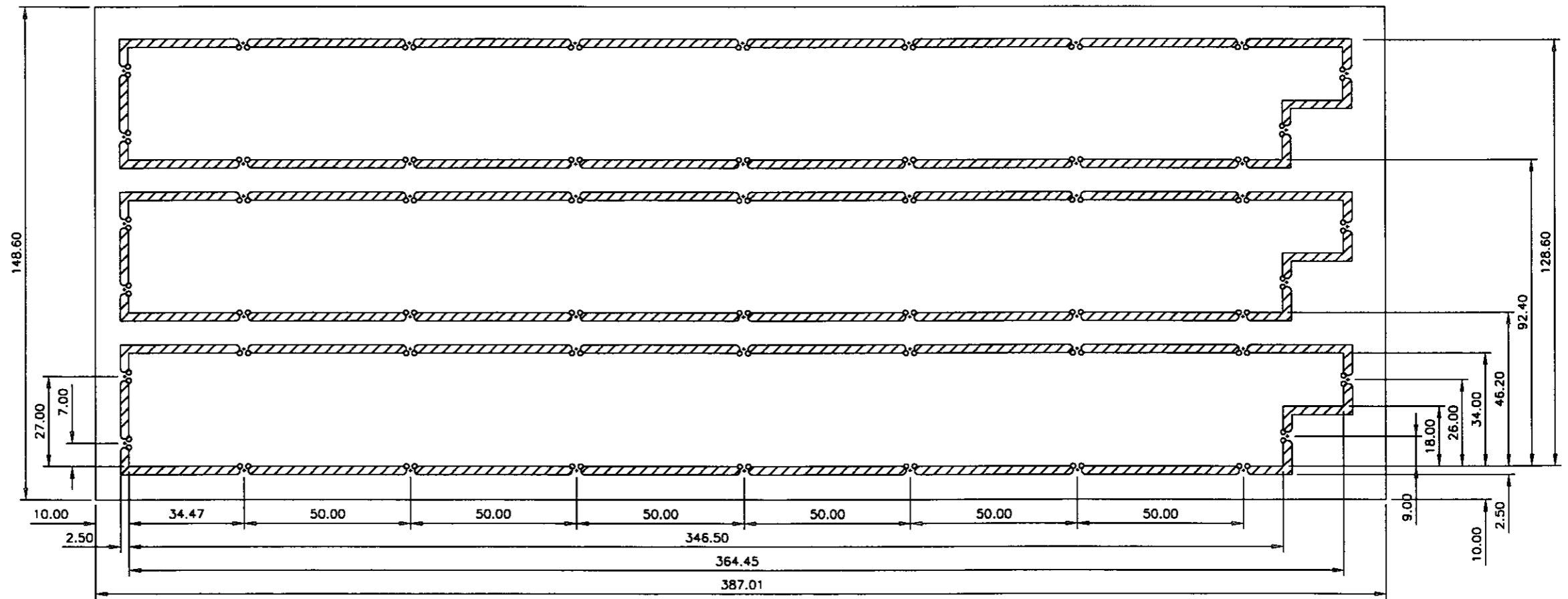

ALL DIMENSIONS ARE IN mm.
DIMENSION TOLERANCE
DIMENSION TO 2 DECIMAL PLACES IS ±0.1mm
DIMENSION TO 1 DECIMAL PLACE IS ±0.25mm

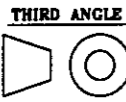

FOR DRILL AND PROFILE DETAILS REFER TO DRAWING S-B261B

THIS DRAWING IS THE COPYRIGHT OF BSS Audio. ALL REPRODUCTION AND COPYING, OTHER THAN THAT FOR LICENSED MANUFACTURERS OWN INTERNAL USE, OR DISCLOSURE OF PART OR WHOLE TO A THIRD PARTY WITHOUT PRIOR WRITTEN AUTHORISATION IS IN VIOLATION OF THE COPYRIGHT.
© BSS Audio. 1995

REMOVE ALL BURRS & SHARP EDGES

DRAWING NUMBER ISSUE
S-B261BA-02

BSS Audio
HARMAN INTERNATIONAL
INDUSTRIES LIMITED
CRANBORNE HOUSE
CRANBORNE ROAD
POTTERS BAR
HERTS
EN6 3JN
Tel 01707 660667
Fax 01707 660755

BSS AUDIO LTD
MASTER

TITLE: 261 FRONT PANEL
SOLDER SIDE ASSY SH1 2 OF 2

FILENAME: S-B261B-02.LAY

DRAWN: PST

DATE: 23/09/99

CHECKED: PT 27/07/00

MATERIALS:

FINISH:
ALL DIMENSIONS IN mm

ISSUE COMMENTS:
1. PRE-PRODUCTION RELEASE
2. PRODUCTION RELEASE 21/07/00

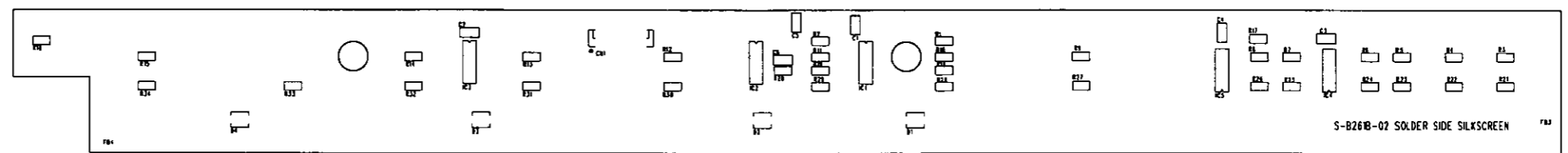

SOLDER SIDE VIEW

DRAWING NUMBER ISSUE
S-B261B-02

SIZE	CON	QTY	SYM
0.508	Yes	93	■
1.55	No	16	○
4	No	6	■
4.25	No	2	■



HARMAN INTERNATIONAL
 INDUSTRIES LIMITED
 CRANBORNE HOUSE
 CRANBORNE ROAD
 POTTERS BAR
 HERTS
 EN6 3JN
 Tel 01707 660667
 Fax 01707 660755

TITLE: B261 FRONT PANEL PCB
 SHT 1 OF 1

FILENAME: S-B261B-02.LAY

DRAWN: PST

DATE: 23/09/99

CHECKED: PT 27/07/00

MATERIALS:

FINISH:
 ALL DIMENSIONS IN mm

MANUFACTURING NOTES:

MATERIAL :
 1.6mm +/- 0.2 THK. GLASS FIBRE
 1 oz CU DOUBLE SIDED
 FLAMMABILITY RATING TO 94-V0

FINISH:
 1. PCB TO FINISHED GOLD
 2. SOLDER RESIST BOTH SIDES IN GREEN
 PHOTOMACABLE
 3. LEGEND ON BOTH SIDES IN WHITE

DRILLING:
 1. SEE DRILL TABLE FOR HOLE SIZES &
 PLATING INFO.
 HOLE SIZES SPECIFIED ARE FINISHED SIZES
 HOLE TOL. +0.15/ -0

SURFACE MOUNT:
 BOTH SIDES -256-
 MIN PAD 0.024" x 0.060"

TRACKING:
 MINIMUM TRACK WIDTH 0.008"
 MINIMUM TRACK SPACING 0.008"

TESTING:
 DOUBLE SIDED BARE BOARD TEST

NOTES:
 TOL. +/- 0.1mm UNLESS STATED OTHERWISE
 DIMENSIONS IN MM UNLESS STATED OTHERWISE

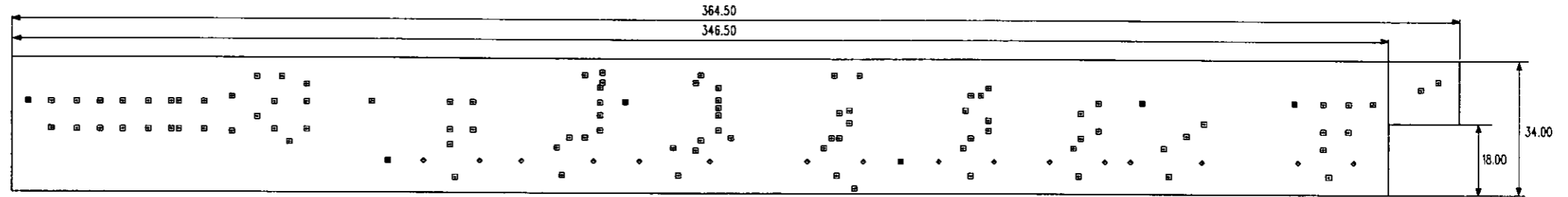

FOR MOTHERPANEL DETAILS REFER TO DWG NO. S-B261BR

ISSUE COMMENTS:

1. PRE-PRODUCTION RELEASE
2. PRODUCTION RELEASE 21/07/00

1oz CU

**BSS AUDIO LTD
 MASTER**

DRAWING NUMBER ISSUE
S-B261BA-02



BSS Audio

HARMAN INTERNATIONAL
INDUSTRIES LIMITED
CRANBORNE HOUSE
CRANBORNE ROAD
POTTERS BAR
HERTS
EN6 3JN
Tel 01707 660667
Fax 01707 660755

BSS AUDIO LTD
MASTER

TITLE: 261 FRONT PANEL
COMP SIDE ASSY

SHT 1 OF 2

FILENAME: S-B261B-02.LAY

DRAWN: PST

DATE: 23/09/99

CHECKED: PT 27/07/00

MATERIALS:

FINISH:

ALL DIMENSIONS IN mm

ISSUE COMMENTS:

1. PRE-PRODUCTION RELEASE
2. PRODUCTION RELEASE 21/07/00

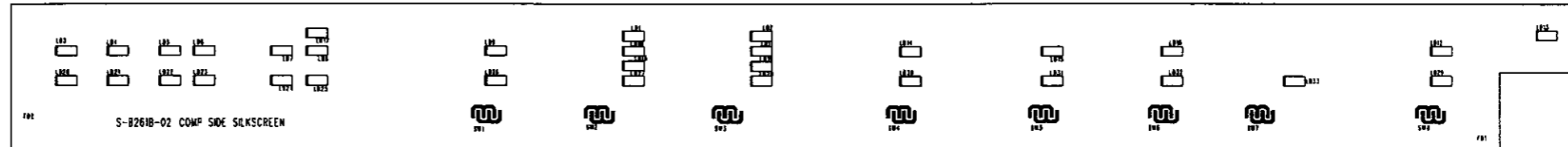

COMPONENT SIDE VIEW