

uncontrolled copy

REVISION HISTORY					
S. C. N.	ZONE	REV	DESCRIPTION	DATE	APPROVED
2			SEE 134783-2.2.XLS FOR PWA DATA AND REVISION HISTORY.	03/19/03	JAW

TOP COMPONENT MAP

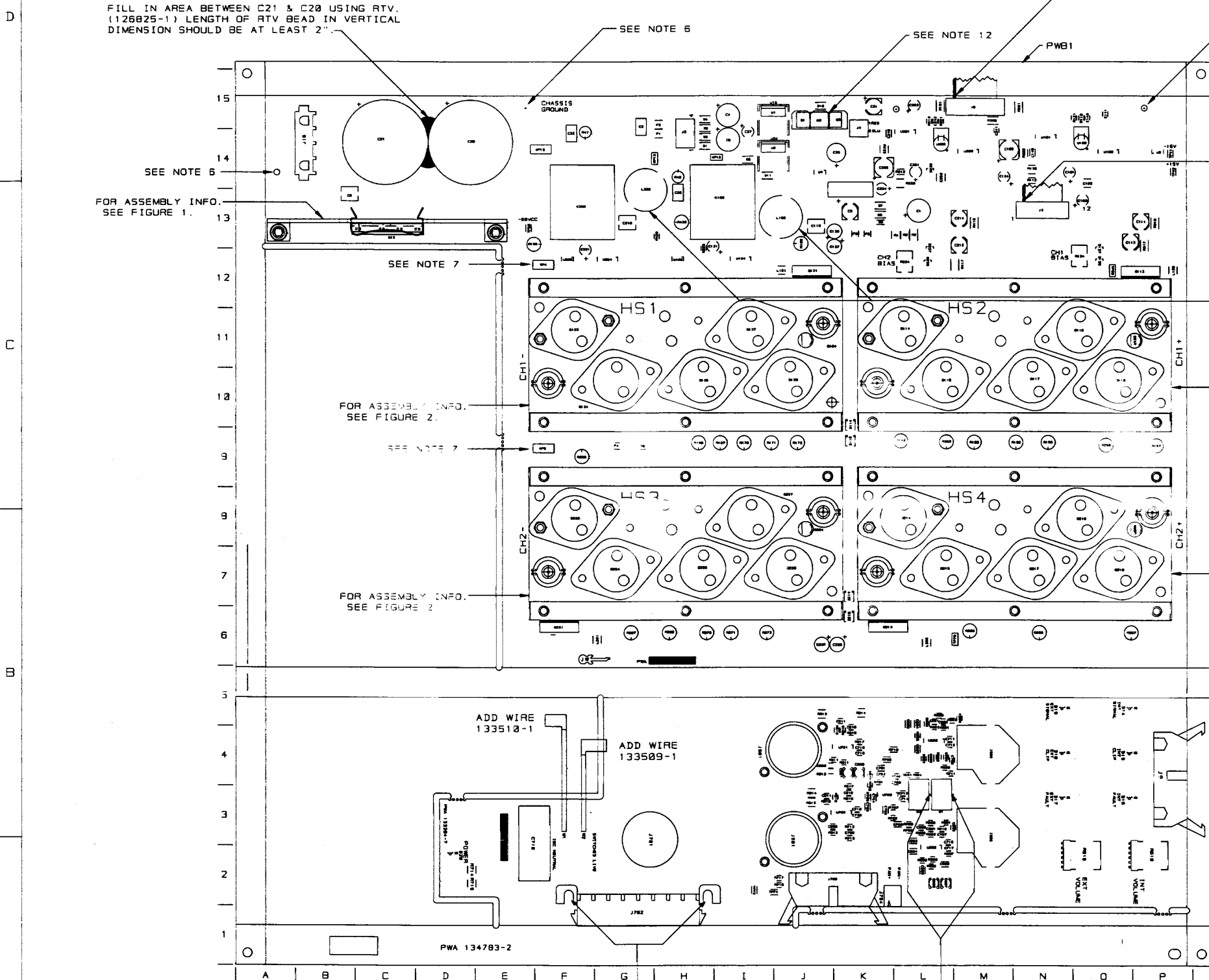

FILL IN AREA BETWEEN C21 & C20 USING RTV. (126825-1) LENGTH OF RTV BEAD IN VERTICAL DIMENSION SHOULD BE AT LEAST 2"

SEE NOTE 12
J6 CABLE ORIENTATION
(STRIPE ON THIS EDGE)

J3 CABLE ORIENTATION
SEE NOTE 11
(STRIPE ON THIS EDGE)

FILL INSIDE OF COILS L102 & 202 WITH RTV (126825-1)
APPLY RTV (126825-1) TO THE INSIDE OF BLACK VINYL CAPS (125242-1). THEN INSERT CAPS OVER COILS

FOR ASSEMBLY INFO.
SEE FIGURE 2.

FOR ASSEMBLY INFO.
SEE FIGURE 2.

FOR ASSEMBLY INFO.
SEE FIGURE 2.

FOR ASSEMBLY INFO.
SEE FIGURE 2.

ADD WIRE
133510-1

ADD WIRE
133509-1

PWA 134783-2

SEE NOTE 13

SEE NOTE 14

UNCONTROLLED
UNLESS OTHERWISE MARKED IN RED INK BY CM AS A CONTROLLED COPY, COPIES OF THESE DOCUMENTS INCLUDING ASSOCIATED ELECTRONIC REPRODUCTIONS ARE FOR REFERENCE ONLY.
THESE DRAWINGS AND SPECIFICATIONS ARE THE PROPERTY OF CROWN INTERNATIONAL, INC. AND SHALL NOT BE REPRODUCED, COPIED, OR USED AS THE BASIS FOR THE MANUFACTURE OR SALE OF APPARATUS OR DEVICES WITHOUT PERMISSION.

DWN	JAW	03/19/03		1718 W. WISHAWACA RD. ELKHART, IN. 45917 PHONE 1219234-8888 WWW.CROWNINTL.COM
CM				TITLE
DISTRIBUTION			PE	
FILENAME			134783-2.2.TIF	
TOLERANCE UNLESS OTHERWISE SPECIFIED			.00 = ±.02" .000 = ±.010" DRILLS = ±.003"	
DO NOT SCALE DRAWING				
SIZE DWG NO.			D 134783-2	
SCALE NONE			SHEET 1 OF 6	
REV			2	

C:\DOCUMENTE~1\ewatts\LOCALS~1\Temp\134783~1.TIF

6/18/2003

uncontrolled copy

BOTTOM COMPONENT MAP

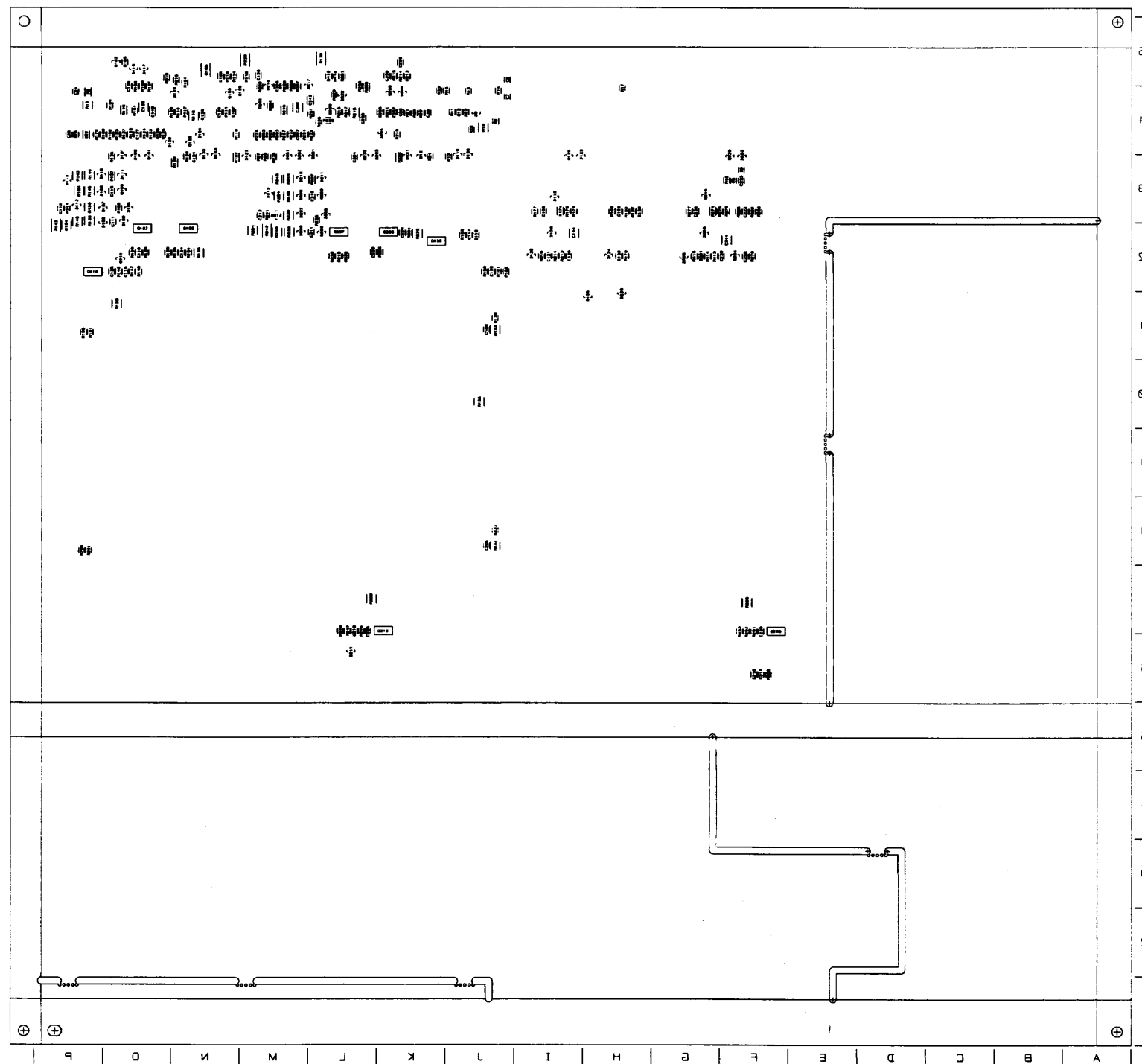

PWA, CJ2000D MAIN

UNCONTROLLED		THESE DRAWINGS AND SPECIFICATIONS ARE THE PROPERTY OF CROWN INTERNATIONAL, INC. AND SHALL NOT BE REPRODUCED, COPIED, OR USED AS THE BASIS FOR THE MANUFACTURE OR SALE OF APPARATUS OR DEVICES WITHOUT PERMISSION.		SIZE	DWG NO.	REV
D		134783-2				2
SCALE	NONE	PROJ. NO.	MD458PB	SHEET 2 OF 8		

C:\DOCUMENTS~1\events\LOCALS~1\Temp\134783~1.TIF

6/18/2003

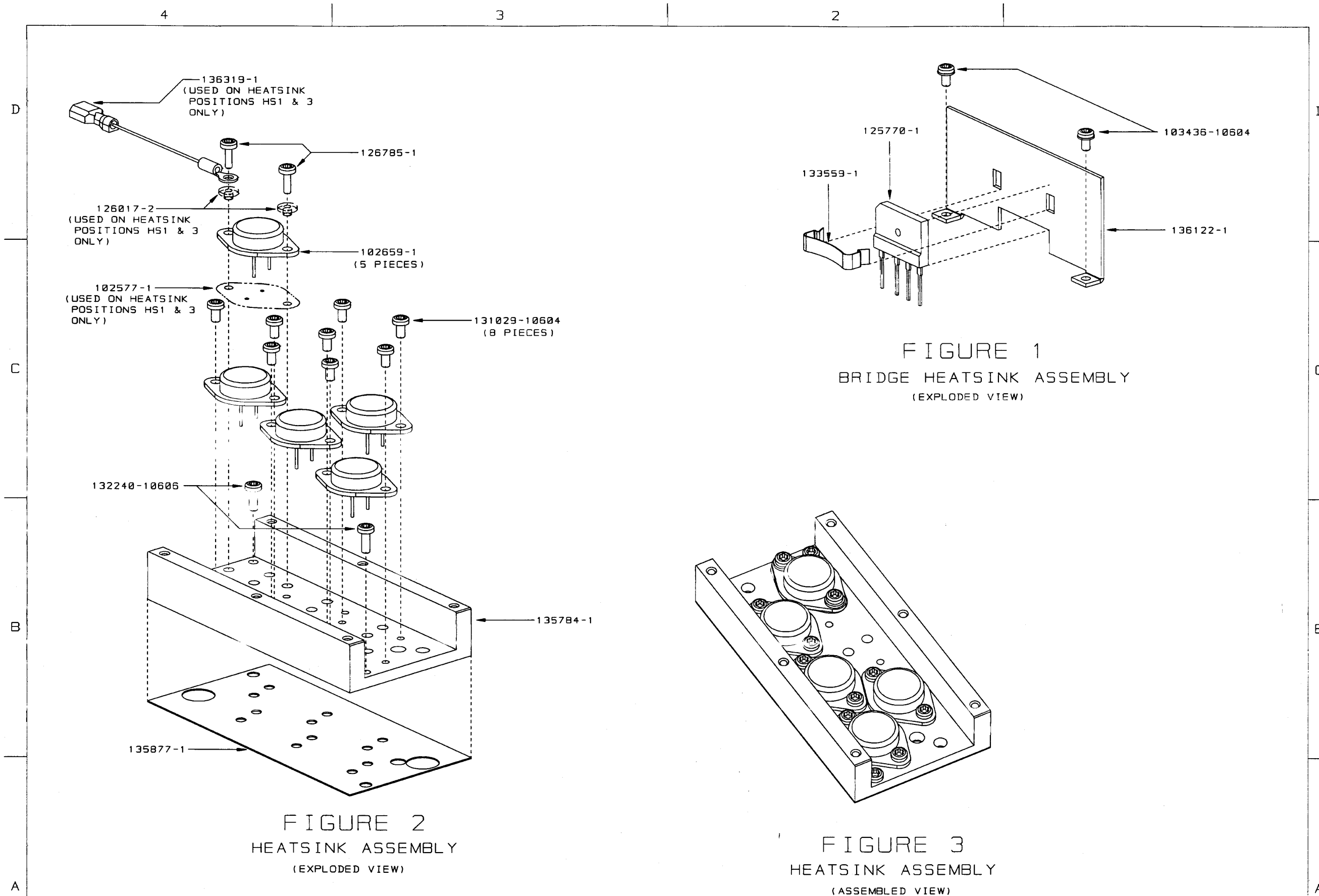

FIGURE 1
BRIDGE HEATSINK ASSEMBLY
(EXPLODED VIEW)

FIGURE 2
HEATSINK ASSEMBLY
(EXPLODED VIEW)

FIGURE 3
HEATSINK ASSEMBLY
(ASSEMBLED VIEW)

PWA, CJ2000D MAIN

UNCONTROLLED UNLESS OTHERWISE MARKED IN RED INK BY CM AS A CONTROLLED COPY. COPIES OF THESE DOCUMENTS INCLUDING ASSOCIATED ELECTRONIC REPRODUCTIONS ARE FOR REFERENCE ONLY.	THESE DRAWINGS AND SPECIFICATIONS ARE THE PROPERTY OF CROWN INTERNATIONAL, INC. AND SHALL NOT BE REPRODUCED, COPIED, OR USED AS THE BASIS FOR THE MANUFACTURE OR SALE OF APPARATUS OR DEVICES WITHOUT PERMISSION.		SIZE	DWG NO.	REV
	SCALE NONE	PROJ NO. MD459P0	134783-2	2	SHEET 3 OF 6

uncontrolled copy

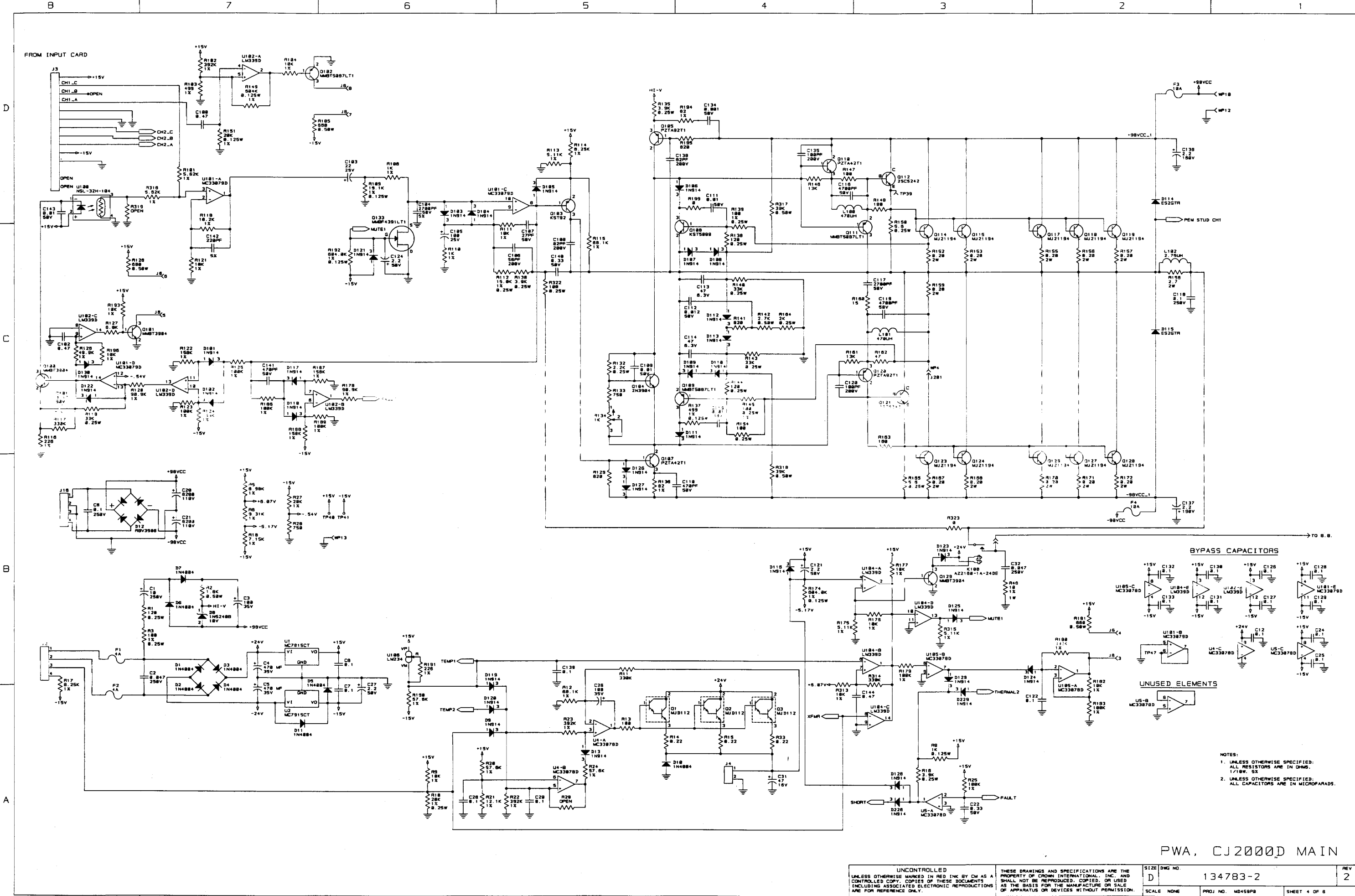

PWA, CJ2000D MAIN

UNCONTROLLED		SIZE	DWG NO.	REV
UNLESS OTHERWISE MARKED IN RED INK BY CM AS A CONTROLLED COPY, COPIES OF THESE DOCUMENTS INCLUDING ASSOCIATED ELECTRONIC REPRODUCTIONS ARE FOR REFERENCE ONLY.		D	134783-2	2
SCALE	NONE	PROJ. NO.	MD459P	SHEET 4 OF 8

6/18/2003

C:\DOCUMENTS AND SETTINGS\LOU\AL-S\Temp\134783-1.TIF

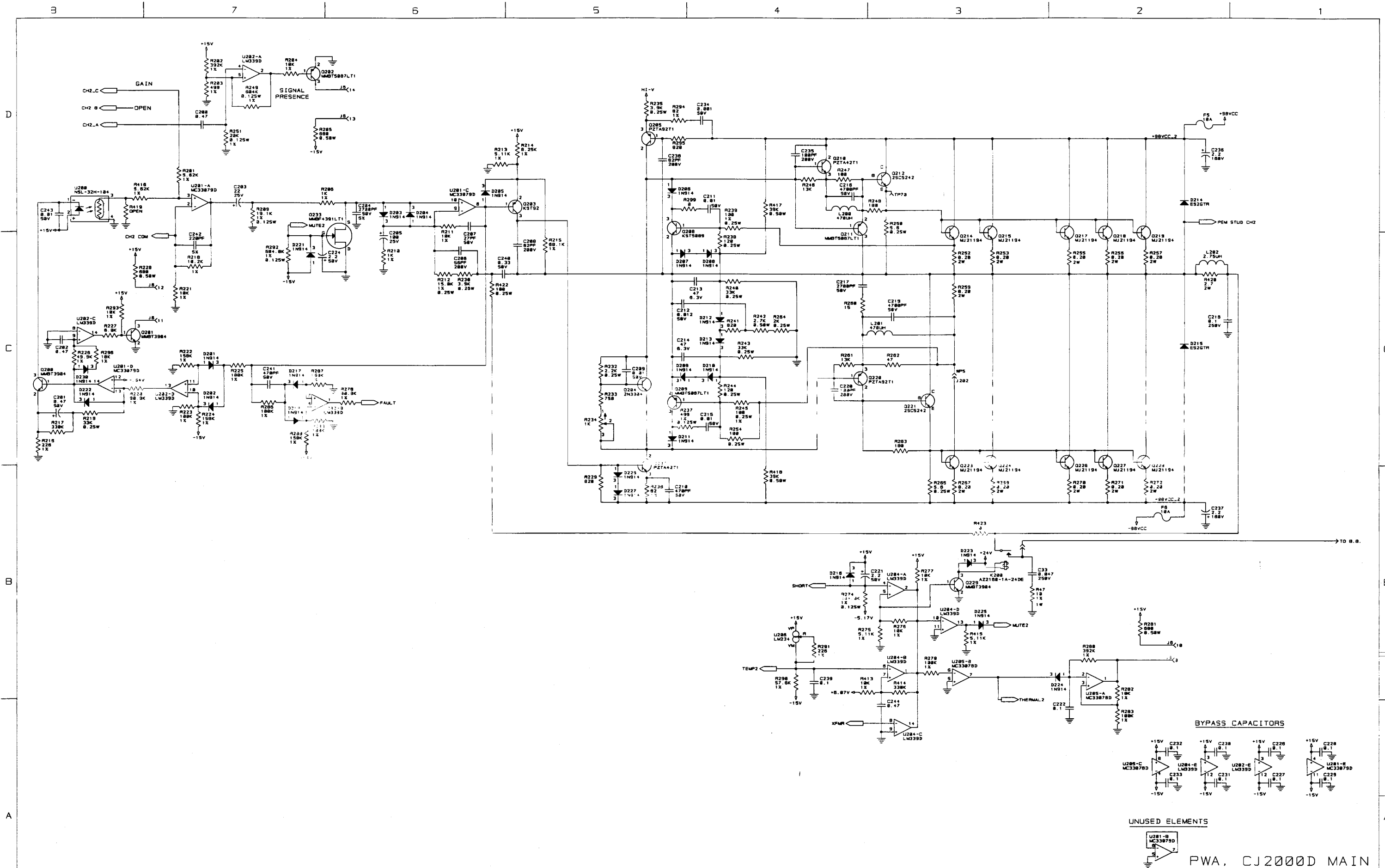

UNCONTROLLED		THESE DRAWINGS AND SPECIFICATIONS ARE THE PROPERTY OF CROWN INTERNATIONAL, INC. AND SHALL NOT BE REPRODUCED, COPIED, OR USED AS THE BASIS FOR THE MANUFACTURE OR SALE OF APPARATUS OR DEVICES WITHOUT PERMISSION.		SIZE	DWG NO.	REV
UNLESS OTHERWISE MARKED IN RED INK BY CM AS A CONTROLLED COPY. COPIES OF THESE DOCUMENTS INCLUDING ASSOCIATED ELECTRONIC REPRODUCTIONS ARE FOR REFERENCE ONLY.				D	134783-2	2
SCALE NONE		PROJ. NO. MD459PB		SHEET 5 OF 8		

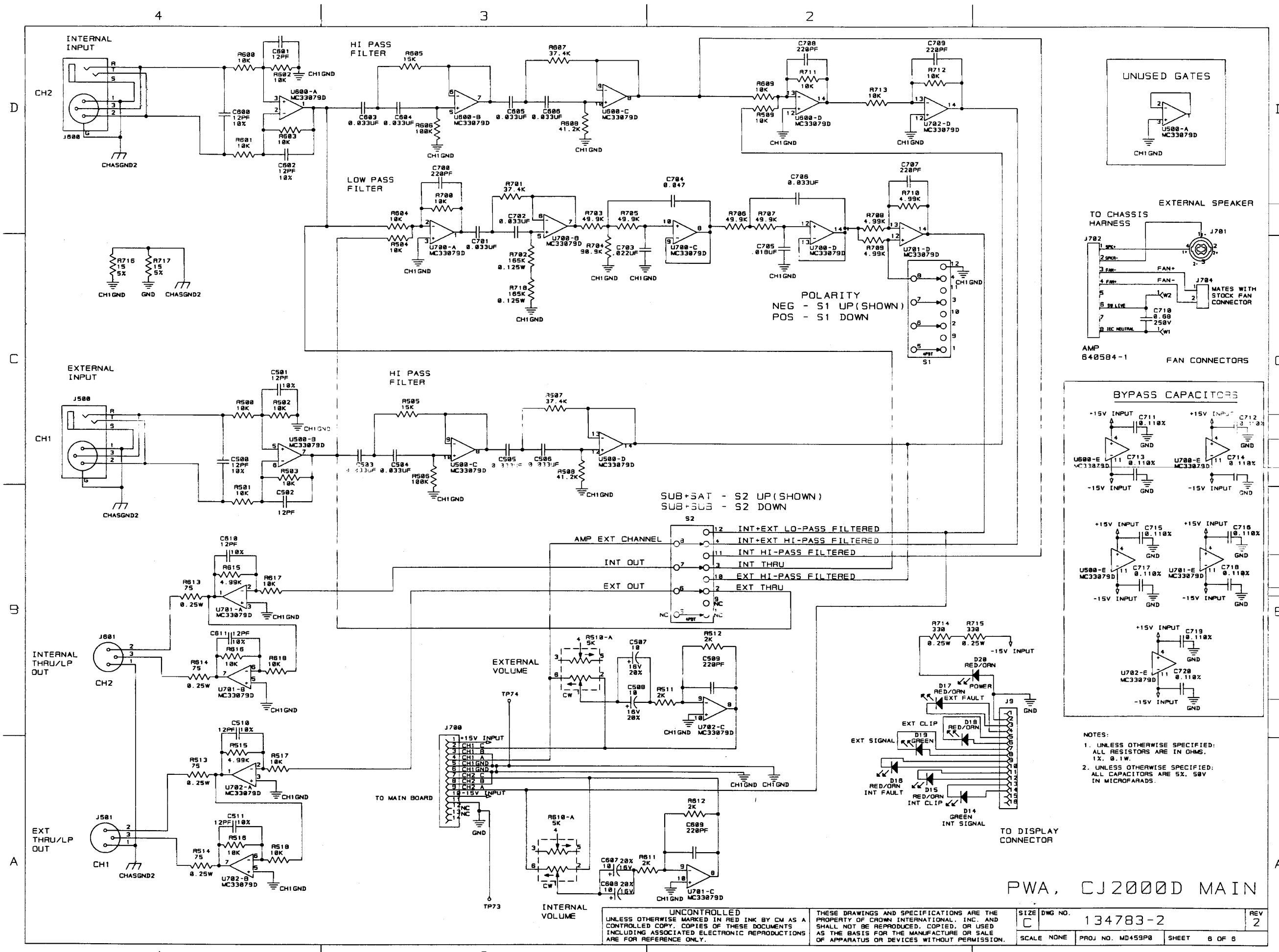

PWA, CJ2000 MAIN

UNCONTROLLED
 UNLESS OTHERWISE MARKED IN RED INK BY CW AS A CONTROLLED COPY. COPIES OF THESE DOCUMENTS INCLUDING ASSOCIATED ELECTRONIC REPRODUCTIONS ARE FOR REFERENCE ONLY.

THESE DRAWINGS AND SPECIFICATIONS ARE THE PROPERTY OF CROWN INTERNATIONAL, INC. AND SHALL NOT BE REPRODUCED, COPIED, OR USED AS THE BASIS FOR THE MANUFACTURE OR SALE OF APPARATUS OR DEVICES WITHOUT PERMISSION.

SIZE	DWG NO.	REV
C	134783-2	2
SCALE	PROJ NO. MD459P8	SHEET 6 OF 6